

THERMOWELL
Weld-in

**Type:
In-Line**

Sheet No.
5-5 V2.1
10123-E221201v3.1



Application:

- For protecting temperature sensors
- For tasks that require easy and quick replacement of temperature sensors without interruption of the process
- For temperature measurement in small pipes
- Thermowell for small pipes

Properties:

- Weld-in pocket
- Quick connect and easy installation
- Quick reactiontime
- Engraved HEAT number
- Surface area of parts with media contact, Mechanically polished <0,8 µm
- Pressure tested up to 40bar

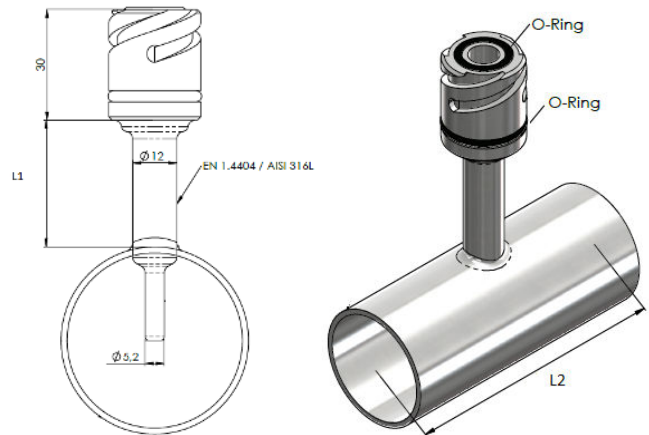

MECHANICAL SPECIFICATIONS:

Protective sheath: -----
Stainless acid-proof steel EN 1.4404 AISI 316L)

Pipe diameter:-----
Ø 3/4" (DN20)
Ø 1" (DN25)
Special

Length L1 -----
50mm
Special

Length L2: -----
90mm
Special

Sensor Mounting: -----
Quick connect

Certificate:-----
1: Certificate: 3.1 Material
2: Certificate of origin
3: Certificate of conformity
4: Surface roughness

Engraved HEAT no.-----
Yes
No

Date:

Part No.